

Supporting you

1300 362 923

www.healthtec.com.au

SPECIALTY

## Ultrasound Table

Designed for the Ultrasound Imaging and Diagnostic Clinics this table provides a comfortable working environment for both the sonographer and the patient.

It's small footprint and unique design means that it can be used in even the smallest of ultrasound rooms.

The low minimum height provides excellent access for patients with limited mobility or for wheelchair transfers, while the working height can easily be adjusted to assist with patient positioning and reduce fatigue on the sonographer or practitioner.

Also available with ultrasound cut out if required.



### Features

Electric Height Adjustment with footswitch

X-Frame Lift action minimises pinch and crush points

Heavy duty individually lockable castors

Durable powder coated rust resistant frame

High quality anti-microbial vinyl & CFC free foam

5 year warranty on frame & electrics

Australian designed & manufactured

### Specifications

250kg Maximum Lifting Capacity (moving)

400kg Maximum Working Load (stationary)

450mm Minimum Height

950mm Maximum Height

610mm Table Width

18400mm Table Length

Manual Backrest adjustment +70° (electric upgrade available)

Manual Legrest adjustment +30° to -90°



Shown with cutout.



### The Healthtec Warranty

All Healthtec™ manufactured items are covered for defects in material or workmanship for 5 years from date of purchase. Original suppliers warranty applies.

TGA AR-00106892-6

© October 2013



Supporting you

www.healthtec.com.au

# PRICE SHEET

## Ultrasound Table

	CODE	QTY
<b>Product Description</b>		
LynX Ultrasound Table (610 wide) w/castors	53501T	
LynX Ultrasound Table (610 wide) w/cutout & castors	53510T	
<b>Width Options</b>		
670mm Width Option	-65	
710mm Width Option	-70	
770mm Width Option	-75	
Custom Width Option	6014	
<b>Foam &amp; Vinyl Options</b>		
75mm Comfort Foam	6005	
Non-Stock Vinyl Option	6018	
Leather Upgrade	6008	
*please refer to our colour chart for vinyl colour options		
<b>Head Section Options</b>		
Nose Hole – Ultrasound Backrest	6011-7	
Nose Hole Plug	6010	
<b>Motor &amp; Footswitch Option</b>		
Electrically Operated Backrest	6031	
Additional Footswitch (1 function)	6020T	
<b>Rail Options</b>		
Side Rails for three section Table (left & right)	5116	
<b>Castor Options</b>		
Central Locking Castors	6037	
Hoist Access Clearance (140mm clearance)	6028	
<b>Table Protection</b>		
Paper Towel Roll Holder	6017	
Disposable Fitted Sheet – 10 per pack	ANWFIT	
<b>Extended Warranty</b>		
10 years Frame & Electrics	7800	
<b>Freight</b>		
Freight charges are not included in our prices. Please contact your Healthtec representative for freight costs and options.		
Shipping Dimensions	2050mm x 850mm x 650mm	
Shipping Weight	80kg (approximately)	

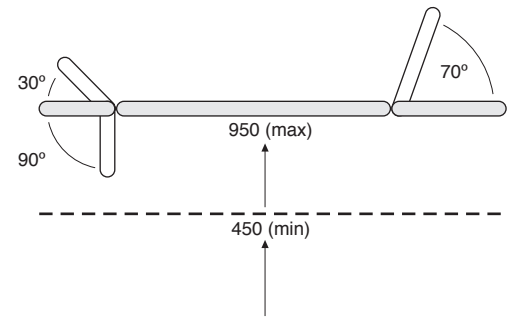
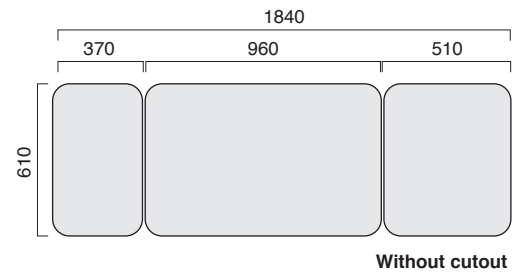
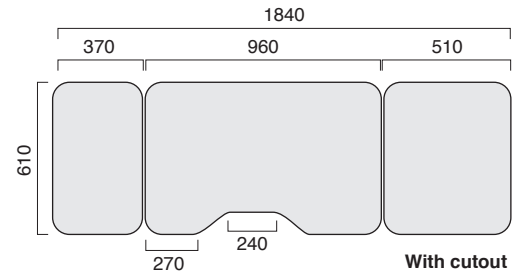

**FRECALL**  
**1300 362 923**  
info@healthtec.com.au

Healthtec Pty Ltd ABN 94 224 518 379 TGA AR-00106892-6  
© October 2013

Disclaimer: Due to our policy of constant product improvement, specifications may change without notice. Check with us for the latest specifications and pricing.

0800 436 324  
www.emech.co.nz  
sales@emech.co.nz